

FIBRECAST PRE-COMPRESSED
MODULE (PCM)

The FibreCast Pre-Compressed Module (PCM) is a compressed and folded blanket module designed mainly for pre-welded stud installations.

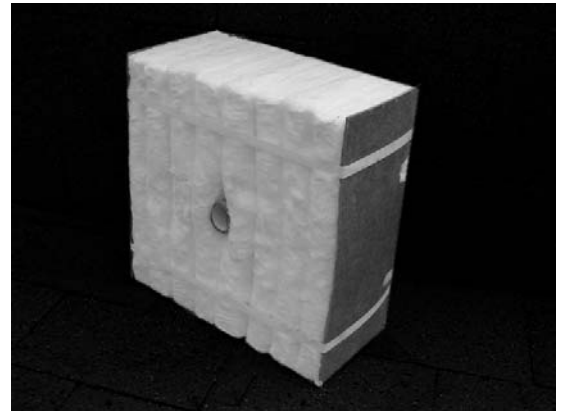

They are constructed from high purity spun ceramic fiber blanket. The PCM incorporates an alignment tube, #304SS yoke and two (2) support tubes. A one-shot weld and bolt system are also available. These modules are compressed with two (2) plastic bands with rigid side panels.

The PCMs can also be manufactured using Hi-Alumina or soluble fibers to meet any design condition.

Standard size is a nominal 12" by 12", although other custom sizes are available upon request. For the complete pre-welded stud system accessories, ask for details or view the Product Data sheet.

AVERAGE CHEMISTRY

| | <u>HP</u> | <u>ZR</u> |
|--------------------------------|-----------|-----------|
| Al ₂ O ₃ | 45% | 30% |
| SiO ₂ | 55% | 53% |
| ZrO ₃ | - | 16% |
| Other | Trace | Trace |

TEMPERATURE USE LIMITS

| | <u>DESIGN</u> | <u>OPERATING LIMIT *</u> |
|----|---------------|--------------------------|
| HP | 2300°F | 2150°F |
| ZR | 2600°F | 2450°F |

* Thickness & Density dependent.

SHRINKAGE (%)

| | <u>HP</u> | <u>ZR</u> |
|----------|-----------|-----------|
| @ 1600°F | 0.5 | - |
| @ 1800°F | 1.0 | - |
| @ 2000°F | 2.0 | 1.5 |
| @ 2200°F | - | 2.4 |
| @ 2400°F | - | 2.8 |

SPECIFICATIONS (PCM)

SIZES: 12" x 12" Nominal

THICKNESSES: 4" to 12", in 1" increments

DENSITIES: 8, 9.3, 10 & 12 PCF

ANCHORAGE SYSTEM:

PRICING & ORDER INFORMATION

TYPE – THK. – SIZE – FIBRE TYPE – DENSITY – ANHORING SYSTEM

e.g. PCM – 8" – 12" X 12" – HP – 9.3 - TS

TYPICAL INSTALLATION

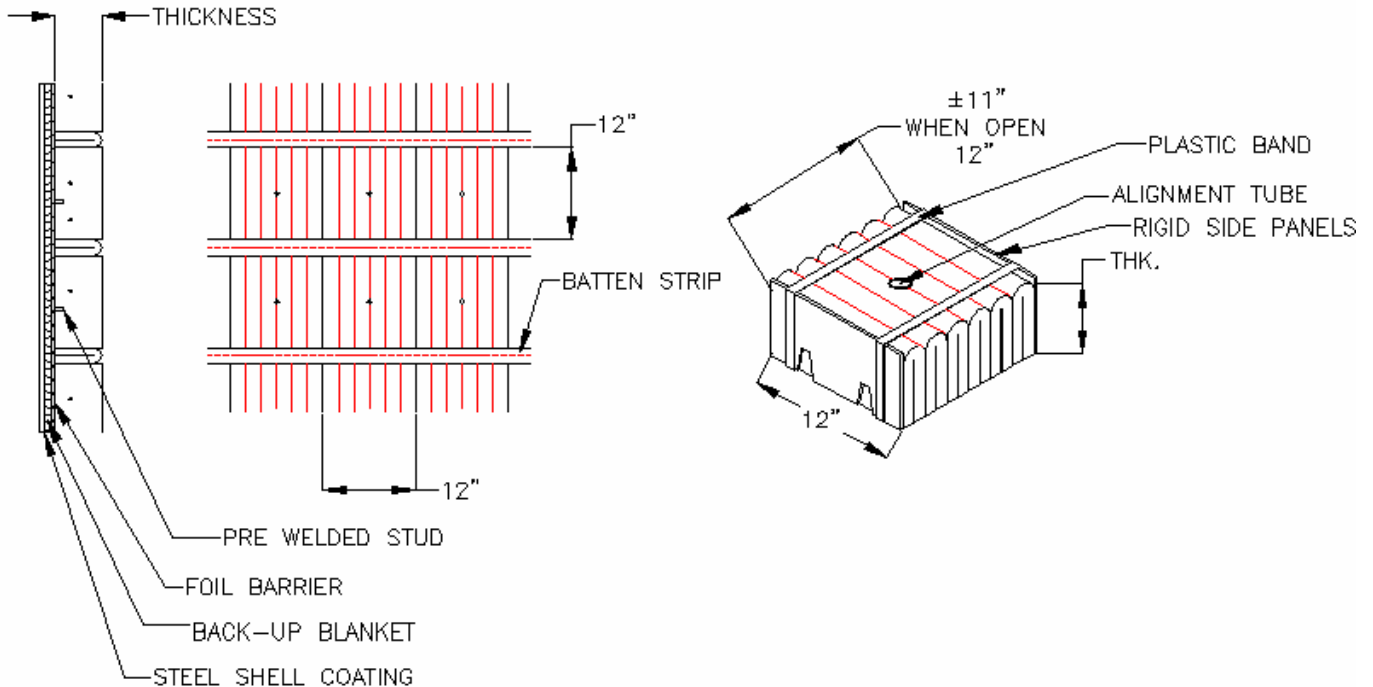

Data listed are average and are subject to variation. Results should not be used for specification purposes. Subject to change without notice.

FibreCast Inc.,
3264 Mainway,
Burlington, Ontario L7M 1A7 Canada

Telephone: 905-319-1080
Fax: 905-319-7611
E-mail: sales@fibrecast.com

MADE IN CANADA

